

INSTALLATION INSTRUCTIONS

CAT 322 L, B & BL EXCAVATORS

MODEL SEQUENCES: 8ML, 9JL, 9RL, 4RM, 1YS, 2ES, 1ZS

Hammond Air Conditioning Ltd.
125 Samnah Cres.
Ingersoll, On.
N5C 3J7
1-800-267-2665
1-888-267-3745 (FAX)

EVAPORATOR:

1. Remove the cowling from behind the seat to expose the heater box.
2. Remove the blower assembly to get at the lower part of the box containing the heater core. Remove the lid to expose the heater core. The lid will have a plug over the area beside the heater core. This will have to be removed for the thermostat probe.
3. Remove the steel caps over the refrigerant line holes through the edge of the box. Remove the cover plate over the open end of the box where the heater core extends out. This will be replaced by the supplied plate in the kit. Remove the caps over the drain tube holes.
4. Place the evaporator assembly in place in the box beside the heater core. The heater control solenoid may need to be rotated to allow the refrigerant lines through the box. Fix the new cover plate into place and secure using the self-drilling screws provided.
5. Seal the area around the flange with silicon. Seal the refrigerant lines with tar tape or silicon. Replace the lid on the box and insert the thermostat probe into the coil approximately 5".
6. Replace the blower assembly onto the heater box. Do not replace the cowling assembly until the system has been leak tested.

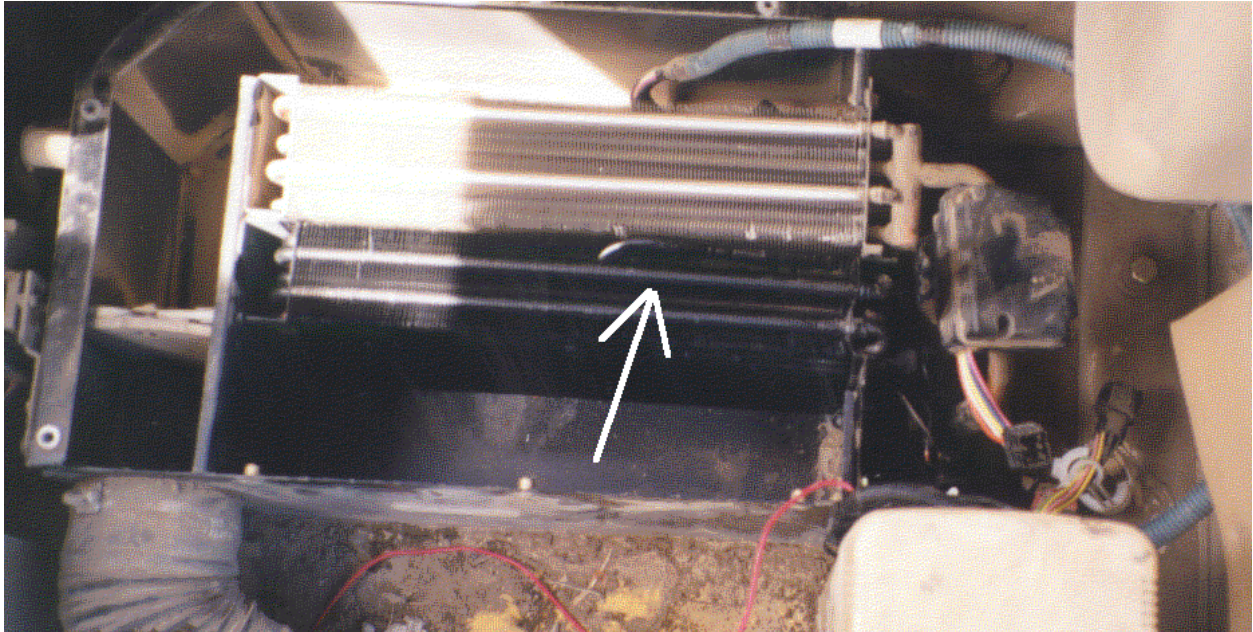

Evaporator (indicated) in place alongside the heater coil in the box. The blower and cover assembly has been removed

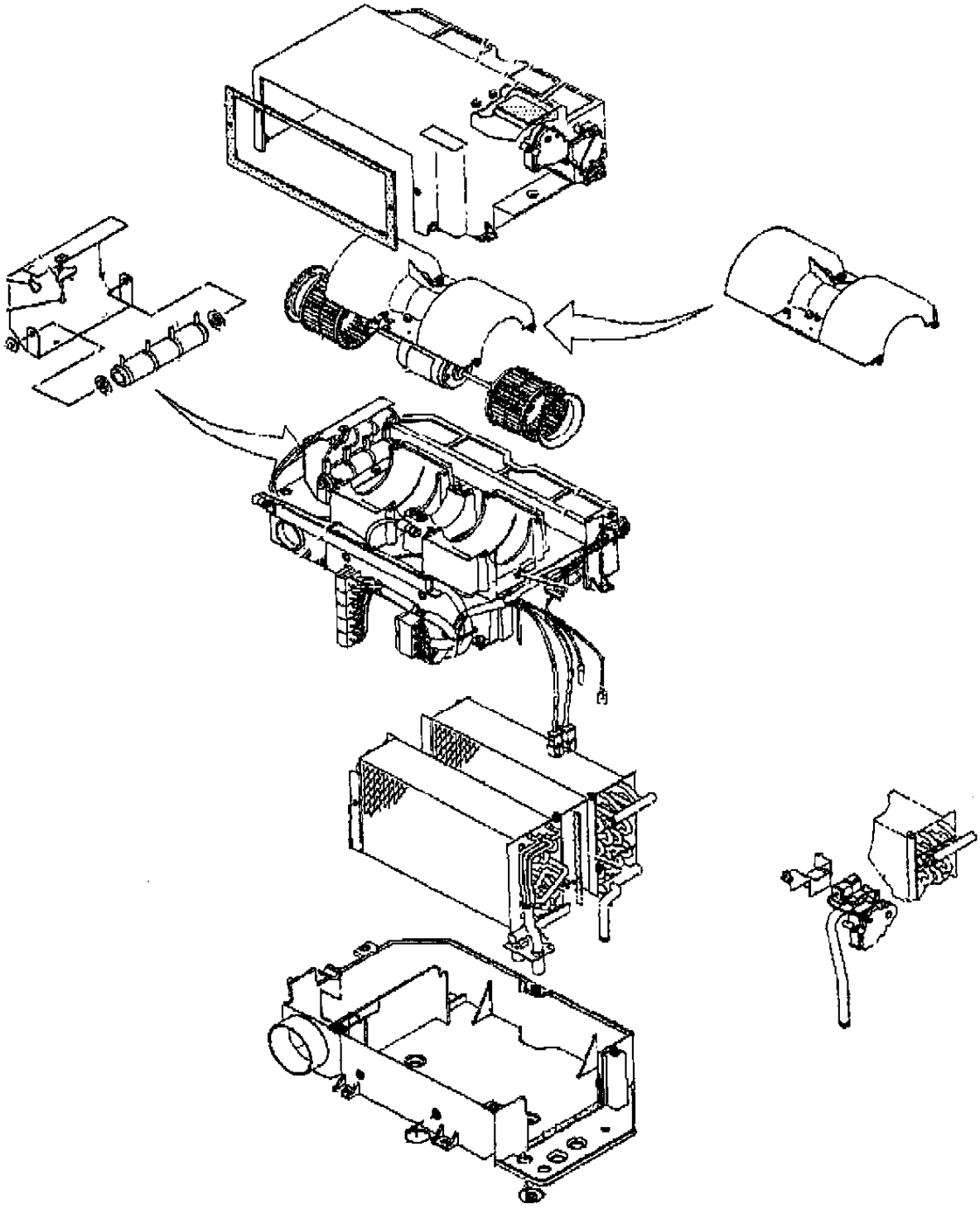

COMPRESSOR:

The compressor mounts to the engine on the location shown in the pictures, on the upper left when facing down the engine toward the fan.

Mount the compressor mount onto the location shown in the pictures using the hardware provided. Do not tighten the mounting hardware down completely until checking the alignment with the compressor in place. Once the alignment is checked, tighten down the bolts and mount the compressor. Place the drive belt in place and tighten up the compressor to take up the tension.

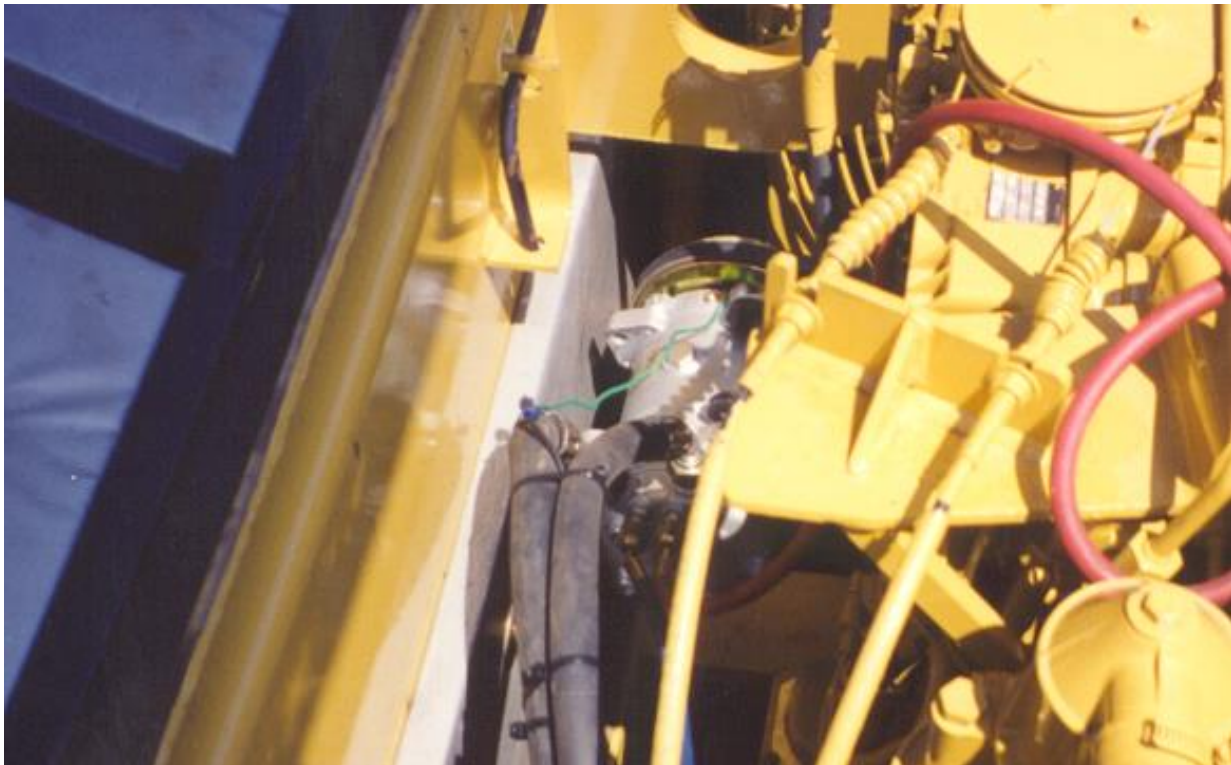

Compressor in place on mount.

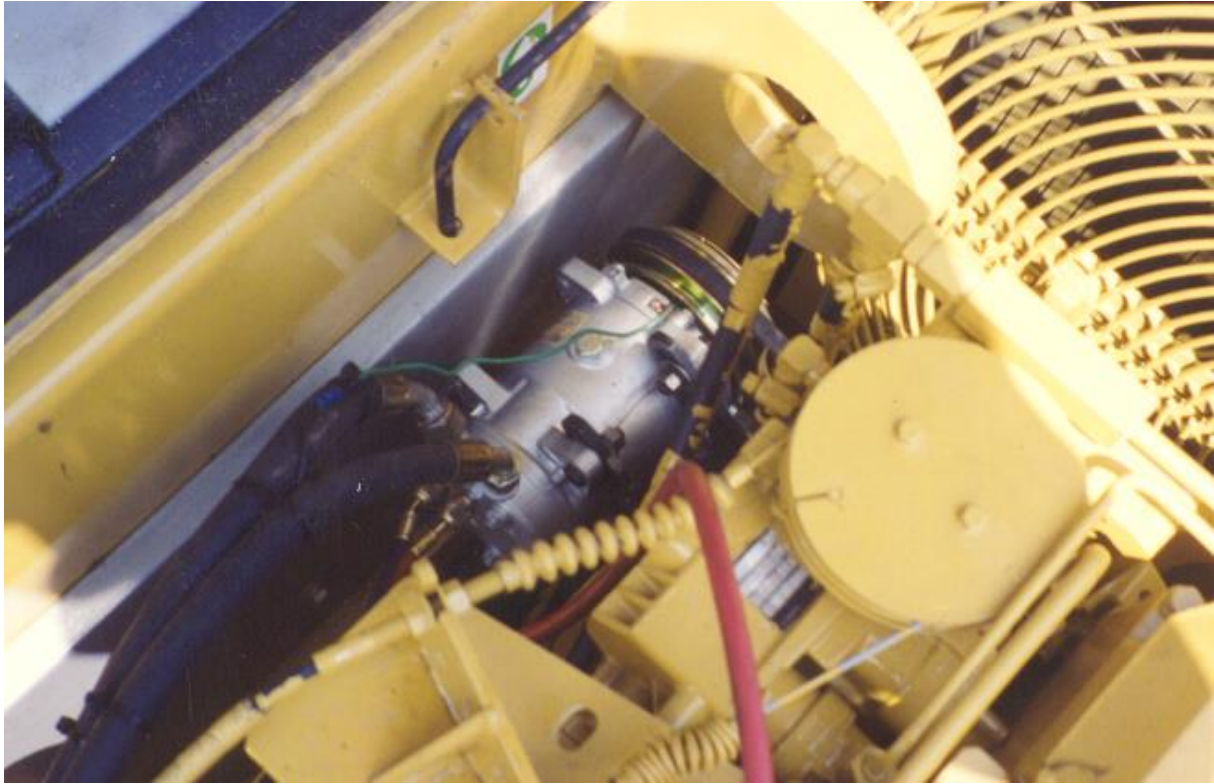

Compressor in place on mount.

CONDENSER MOUNTING:

The condenser is configured for mounting on the radiator as shown in the pictures. The receiver drier is mounted on the condenser frame assembly.



Condenser in place with attached drier and hoses (322L).

On the 322B series excavators the only difference is that spacers are used to stand the frame off of the area surrounding the radiator. See the picture below.



Condenser in place on 322B series excavator.

HOSE RUNS:

5/16" Hose Drier to Evaporator:

The 5/16" hose runs from the drier mounted on the condenser brackets through under the cab to the fitting extending down from the evaporator.

13/32" Hose Compressor to Condenser:

The 13/32" hose is run from the compressor to the condenser out of the engine compartment alongside the radiator and out to the condenser as shown in the pictures.

The fittings are already crimped in place on the hose and the assembly has been pressure tested. The fitting with the charge port is installed at the compressor.

5/8" Hose Compressor to Evaporator

The 5/8" hose runs from the compressor to the evaporator through the engine compartment and under the cab to the fitting on the evaporator.

The fittings on the hose have already been crimped in place and the assembly pressure tested. The hose is run through the engine compartment with the 13/32" hose and then to the evaporator with the 5/16" hose. The fitting with the charge port is to be installed at the compressor.

Hose-wrap exposed sections and any places the hoses may rub. Secure using cable ties and clamps where necessary. Use refrigerant oil on the O-rings at the sealing surfaces to ensure a proper seal.

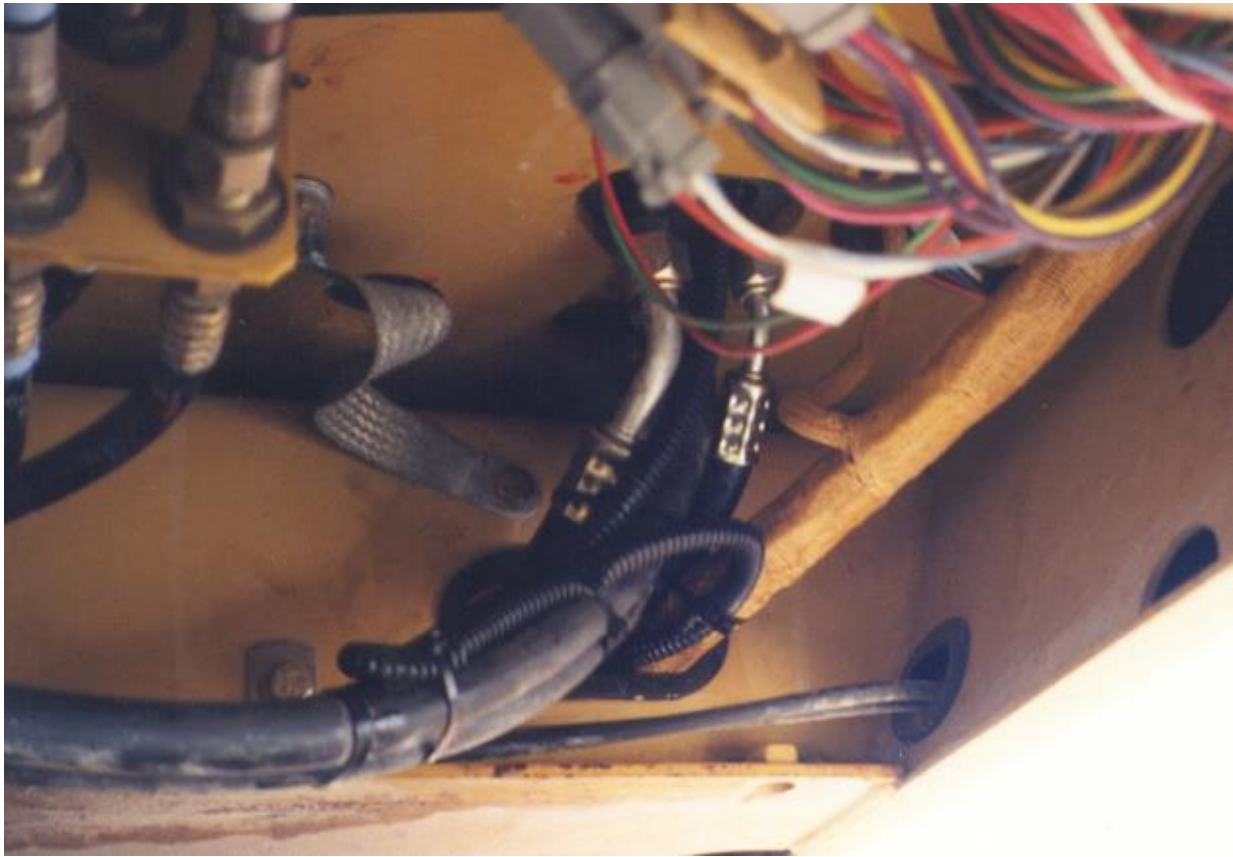

View showing underside of evaporator area with hose assemblies and drain tubes.

ELECTRICAL:

Power to control the thermostat and clutch comes off the heater power wire (#124). Hook into the wire using an instant power tap and connect to the thermostat switch. From the switch run down to the pressure switches and to the compressor. See the wiring diagram for the electrical hook ups.

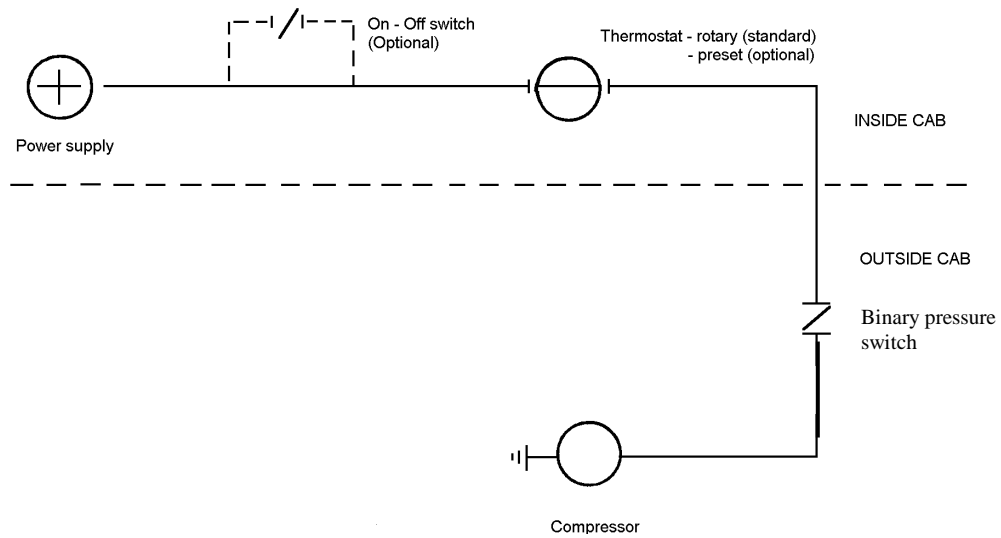

Refrigerant Flow Pattern in a Standard Air Conditioning System

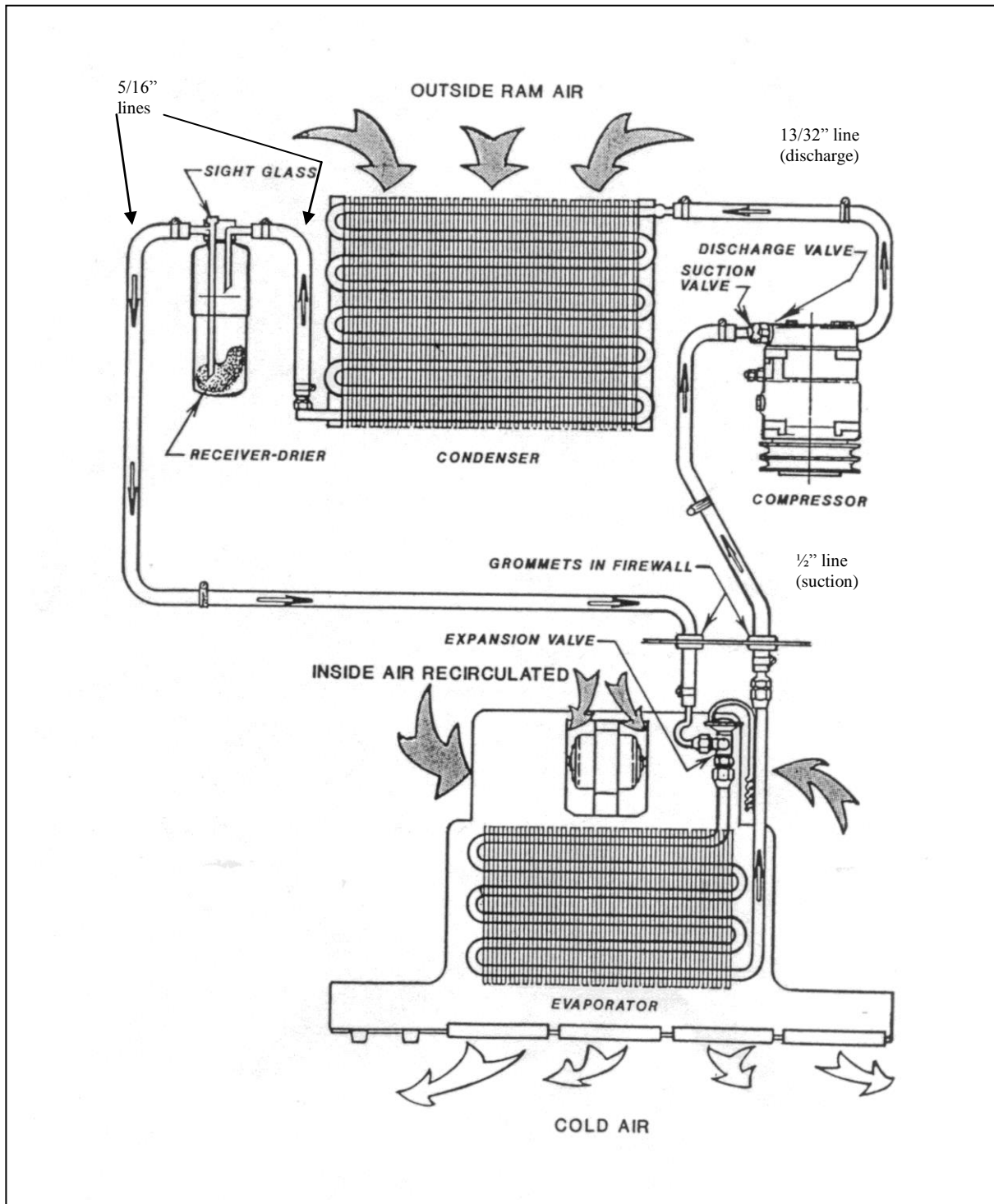

Thermostat Setting Procedures

- 1) Thermostat types
 - a) preset
 - b) adjustable

- a) A preset thermostat is adjusted to its specific cut in and cut out temperatures when manufactured and does not have a rotary adjustment for the operator.
- b) An adjustable or rotary thermostat has been manufactured to a predetermined cut in and cut out temperatures, but it is also operator adjustable to achieve the desired comfort level.

Both types of thermostats can have their factory settings adjusted by turning the setting screws on the body of the thermostat. One body type has the setting screws mounted externally and labeled for direction of rotation. The other body type requires the removal of the plastic end plate to expose the set screw.

- 2) Thermostat probe location: The location of the thermostat probe in an evaporator coil can be very important to achieve the maximum cooling potential of the coil while also preventing coil freeze-up. There is no set location for the thermostat probe to be put that will be optimum for all systems, but several rules of thumb may be followed:
 - a) Insert the probe in the coldest area of the evaporator coil.
 - b) Insert the probe from the top of the coil down, if possible.
 - c) Make sure that at least the last 3" of the thermostat probe are in the coil.

To find the most likely area where the coil is the coldest, consider these factors:

- 1) Direction of air flow through the coil.
 - 2) The coil area likely to have the lowest air flow.
 - 3) The inlet locations of the refrigerant into the coil.
 - 4) The inlet of the hotter outside air into the coil area.
-
- 1) Usually the coldest side of the evaporator coil will be the air outlet side. Often the thermostat probe can be inserted between the last and second last row of tubes.
 - 2) The lower air flow area of the evaporator coil in most systems tends to be near either end of the coil. These areas will be colder
 - 3) The area of the coil that the refrigerant inlet tube(s) occupy should be the coldest part of the coil.
 - 4) If the system is equipped with an outside air intake, where and how that air is brought into the evaporator area can have a large effect on the coil temperature. If all the outside air is piped into the evaporator in one area, that area will be considerably warmer in hot weather.

By looking at all these different factors, the area of an evaporator coil most likely to be the coldest can be determined.

Once the probe is inserted, the A/C system needs to be tested. Run the system to ensure that the thermostat is cycling the compressor off at the appropriate temperature. A core temperature ranging between 25° and 30° F should cause the thermostat to cycle off. The air temperature at the vent outlet closest to the evaporator coil should be between 38° F and 45° F when the compressor cycles off.

If the thermostat doesn't cycle off after a reasonable cool down period, and the air outlet temperature has dropped below 40° F, the cut in and cut out settings should be adjusted until the compressor is cycling on and off regularly. Let the system run for a decent time period (at least 15 min) and then check the evaporator coil for any signs of freezing.

Aeroquip E-Z Clip Assembly Instructions

Step 1. Cut the hose to proper length with an appropriate cutting tool. Aeroquip's hand held hose cutter has been specially designed for cutting all non-wire reinforced hose, such as GH-134 Multi-Refrigerant hose. Be sure the cut is made square to the hose length.

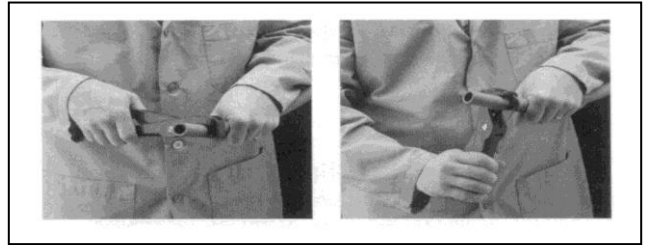

Step 2. Install two proper-sized clips onto the cut end of the hose. Orientation of the clips does not affect the performance of the connection. However, for ease of assembly, both clips should have the same orientation.

NOTE: Failure to slide the clips over the hose at this time will require the clips to be stretched over the hose or fitting later. This may permanently damage the clip.

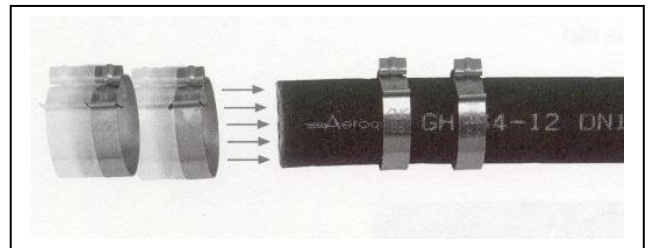

Step 3. Lubricate the nipple with a generous amount of the refrigeration or A/C system's compressor lubricating oil. This **MUST** be done to lower the force of nipple insertion.

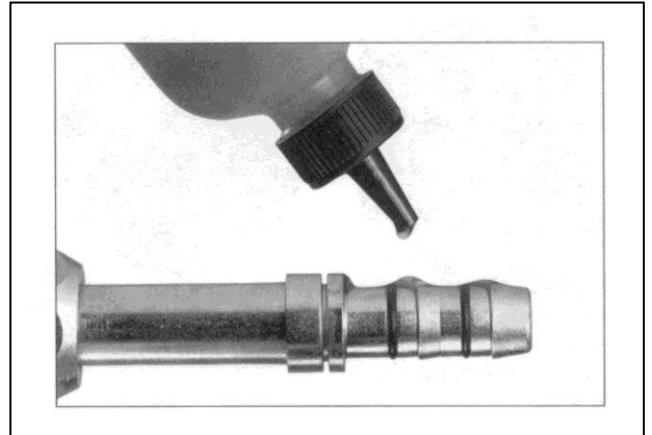

Step 4. Insert the nipple into the hose. To ensure that the nipple is fully inserted, check the gap between the cut end of the hose and the shoulder on the nipple. Care should be taken to avoid kinking or other damage to the hose during nipple insertion. NOTE: Be sure to wipe excess oil from the nipple and hose.



Step 5. Snap the cage into the groove on the nipple. The arms should extend over the hose length. When the cage has been correctly installed in the cage groove, the cage will be able to rotate in the groove. This step **MUST** be performed to ensure:

1. The clips will be located over the O-rings on the nipple.
2. The connection will be compatible with the connection's pressure rating.

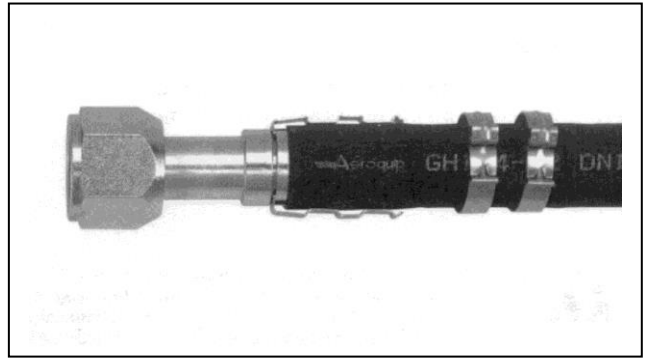

Step 6. Slide the clips over the cage arms and into the channels on each arm.

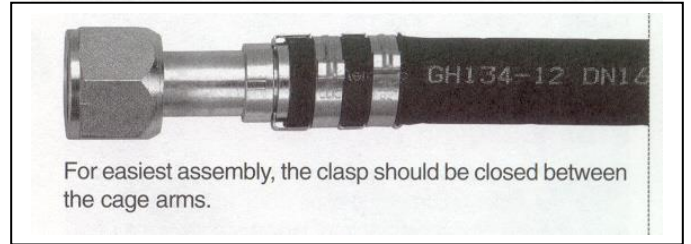
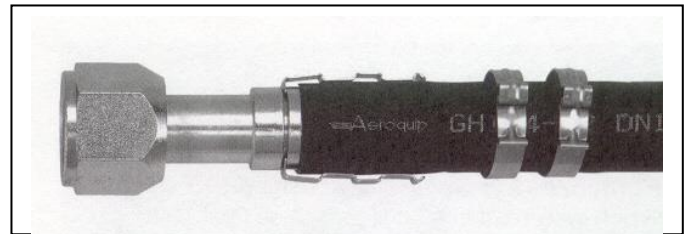

Step 7. Use the pliers to close the clips. The pliers should be positioned squarely on the clip connection points and should remain square during the closing of the clip.

NOTICE: E-Z Clip components should not be reused.

